

DETAIL OF MOUNTING BLOCK

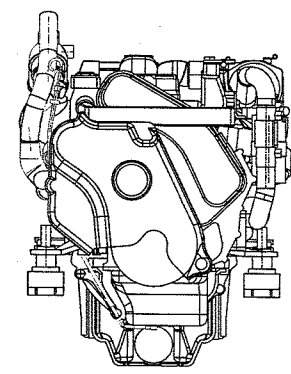

DETAIL OF COUPLING

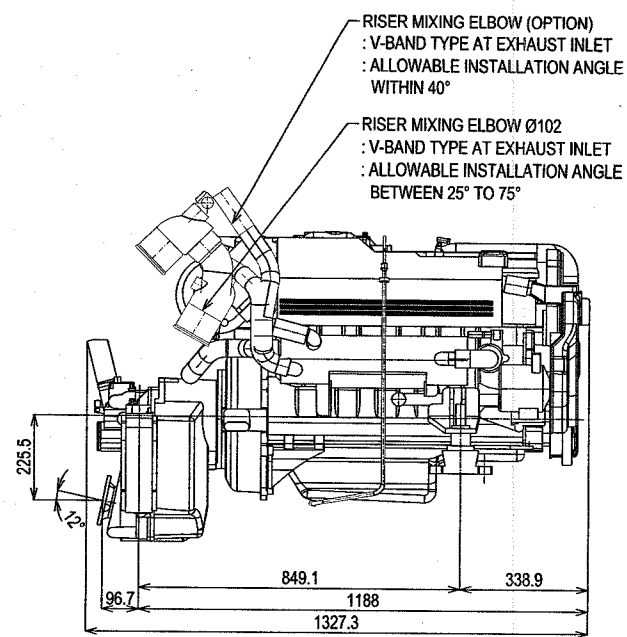
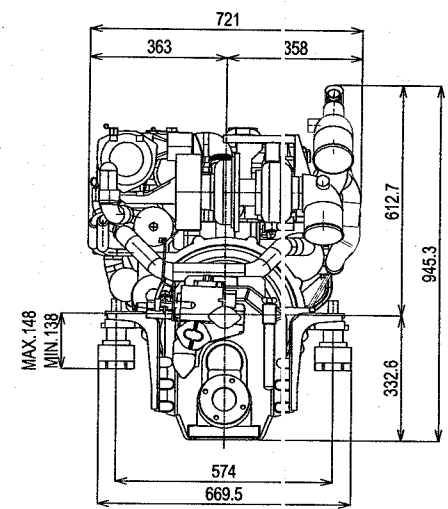
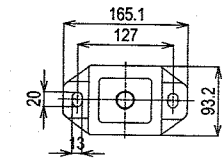
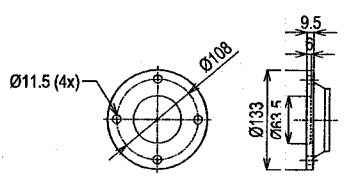

DIRECTION OF ROTATION

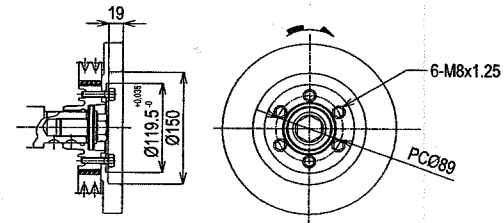

DETAIL OF PULLEY VIEWED FROM A

NOTE:

1. DWG. SHOWS MOUNTING BLOCKS AT ORIGINAL HEIGHT. ENGINE WEIGHT WILL COMPRESS BLOCKS BY 4MM (APPROX).
2. MOUNTING BLOCKS ARE EQUIPPED FOR STANDARD ACCESSORY.
3. Ⓞ SHOWS THE CENTER OF GRAVITY.
4. FOR ADDITIONAL INSTALLATION INFORMATION AND SPECIFICATIONS PLEASE REFER TO THE YANMAR ENGINE INSTALLATION MANUAL

Size	LP	Engine	6LPA-STP2xKMHS0V	Release	R2009-01
Scale	1:10	Date	01-12-09	Dimension	mm

