

CAREER

ISSUE THE DRAWING FOR MASS PRODUCTION. (YDSBD-05003)  
 REV.1(24th.May.2005)  
 CHANGE THE PIPING OF CSW BY CHANGING TO THE CAC OF MOTA (YDSBD-05004)(NISHINO)

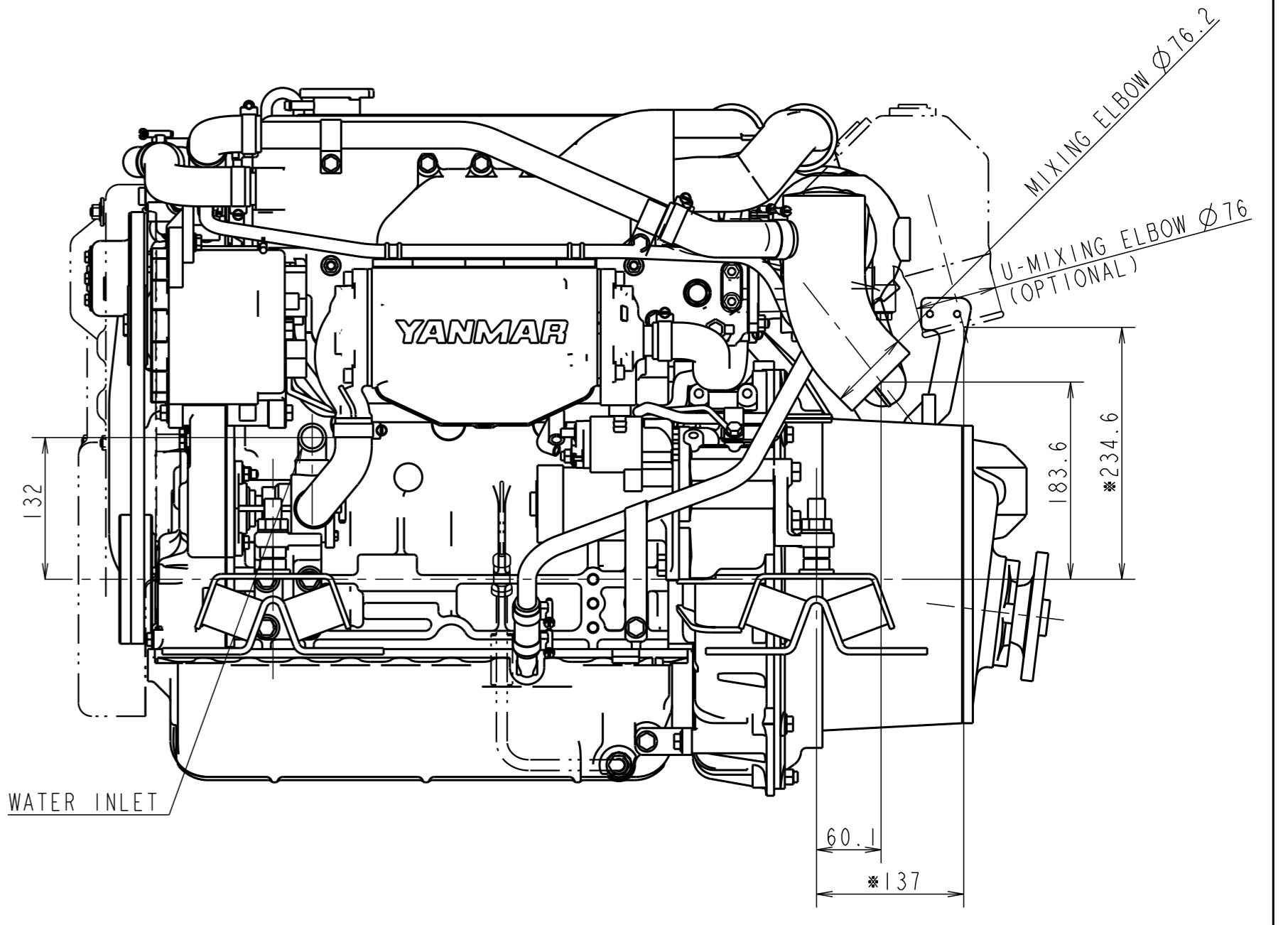

BE CAREFUL SPACE BETWEEN ENGINE BED AND OIL FILTER.

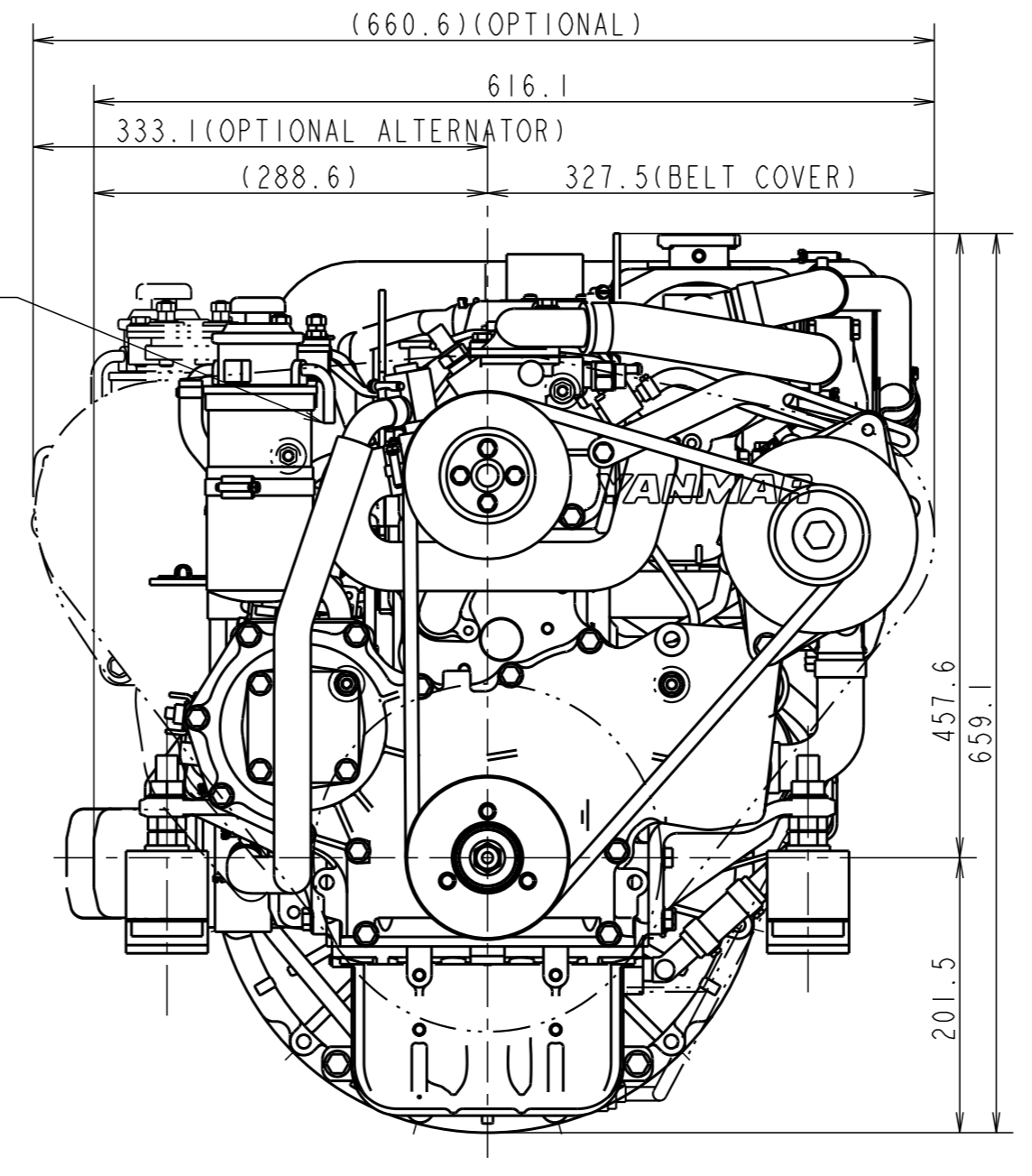
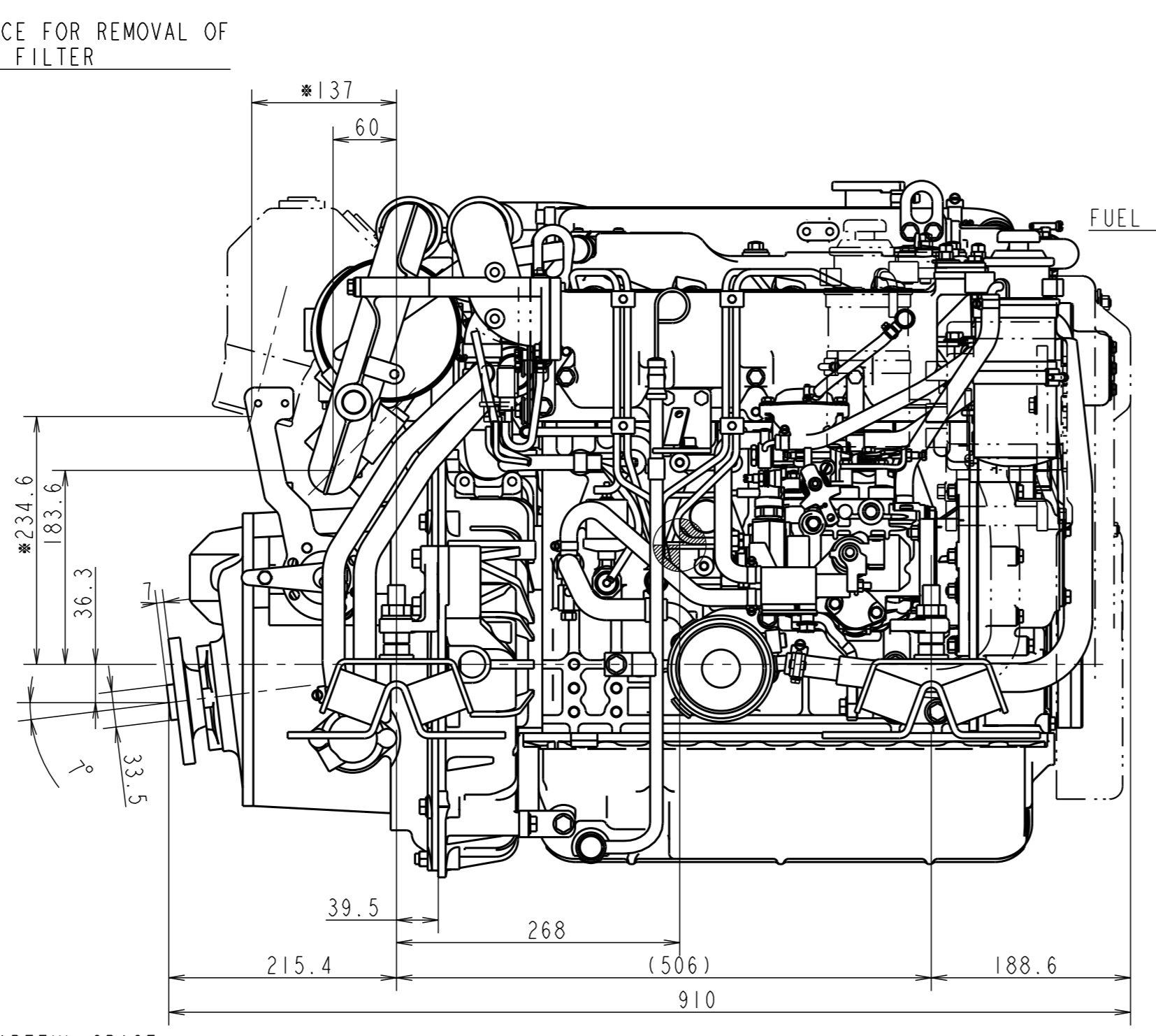
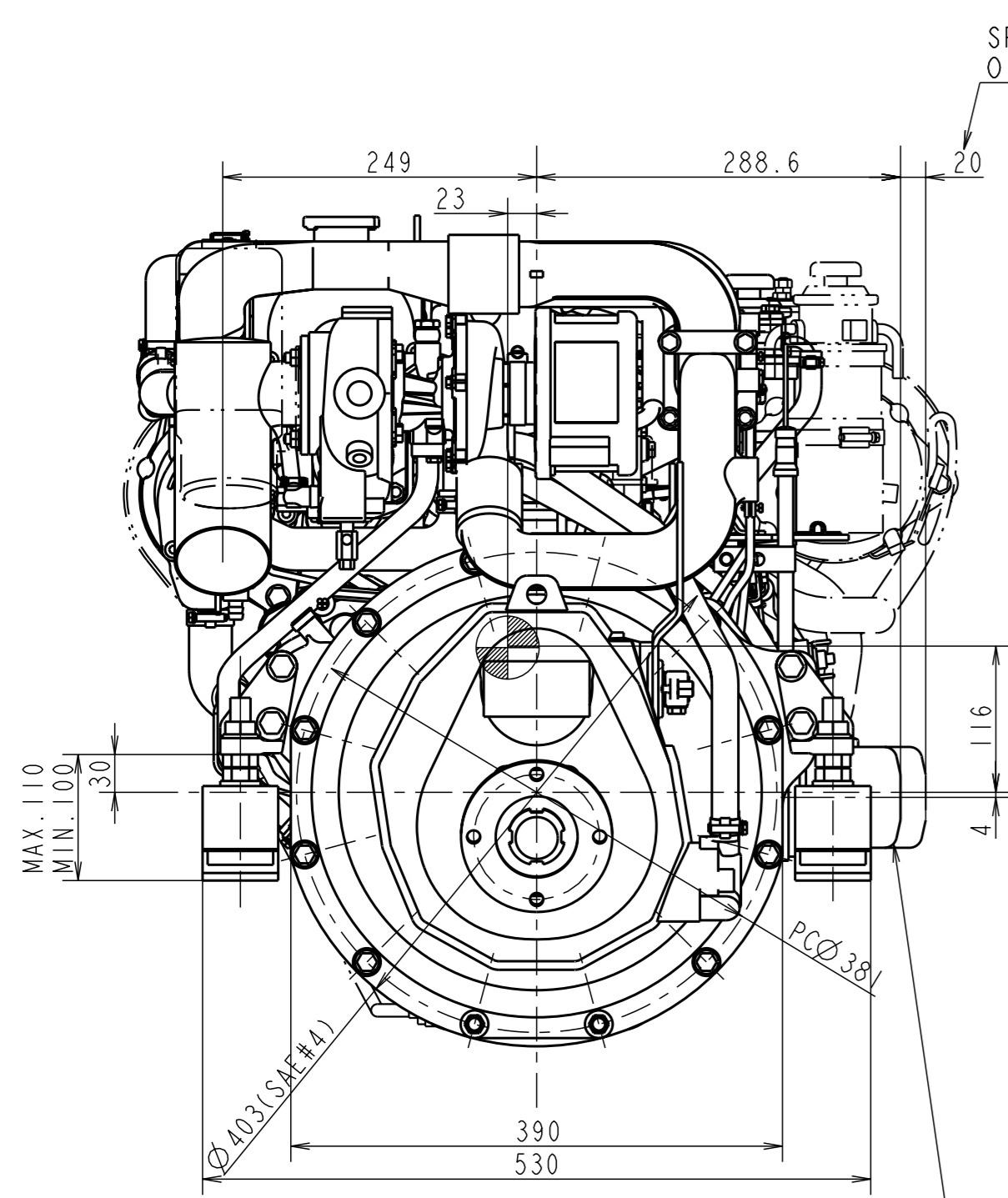
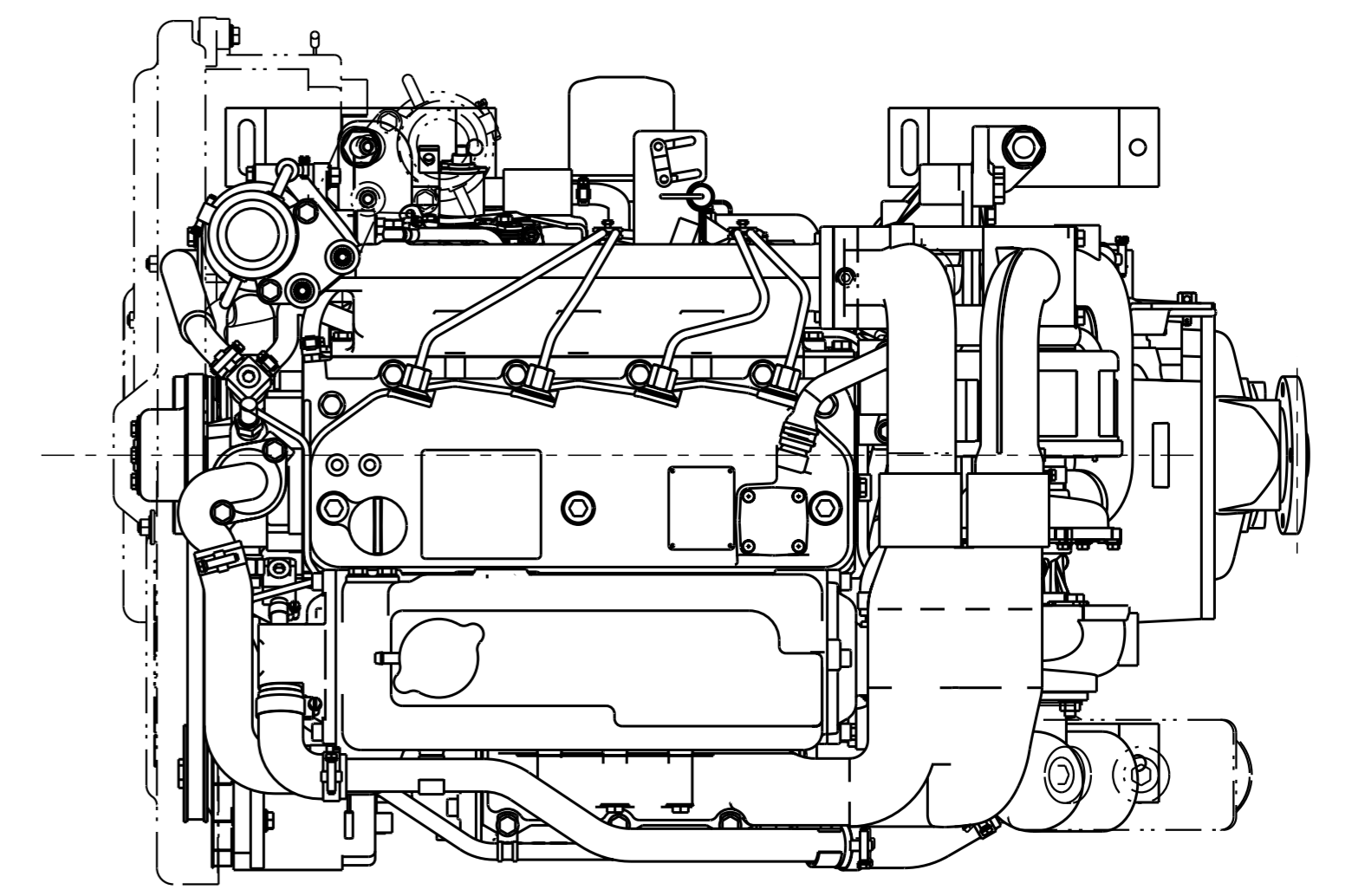
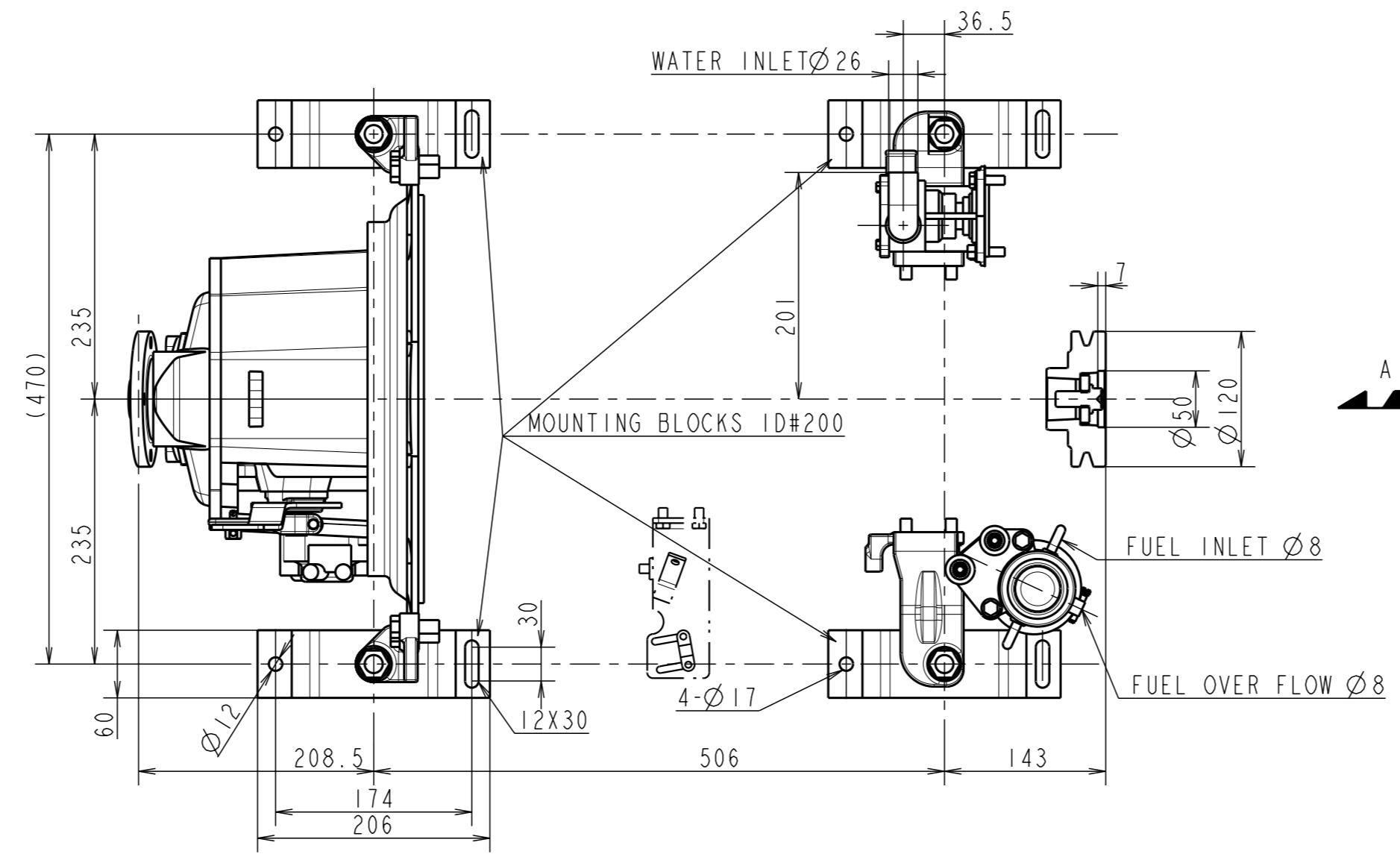
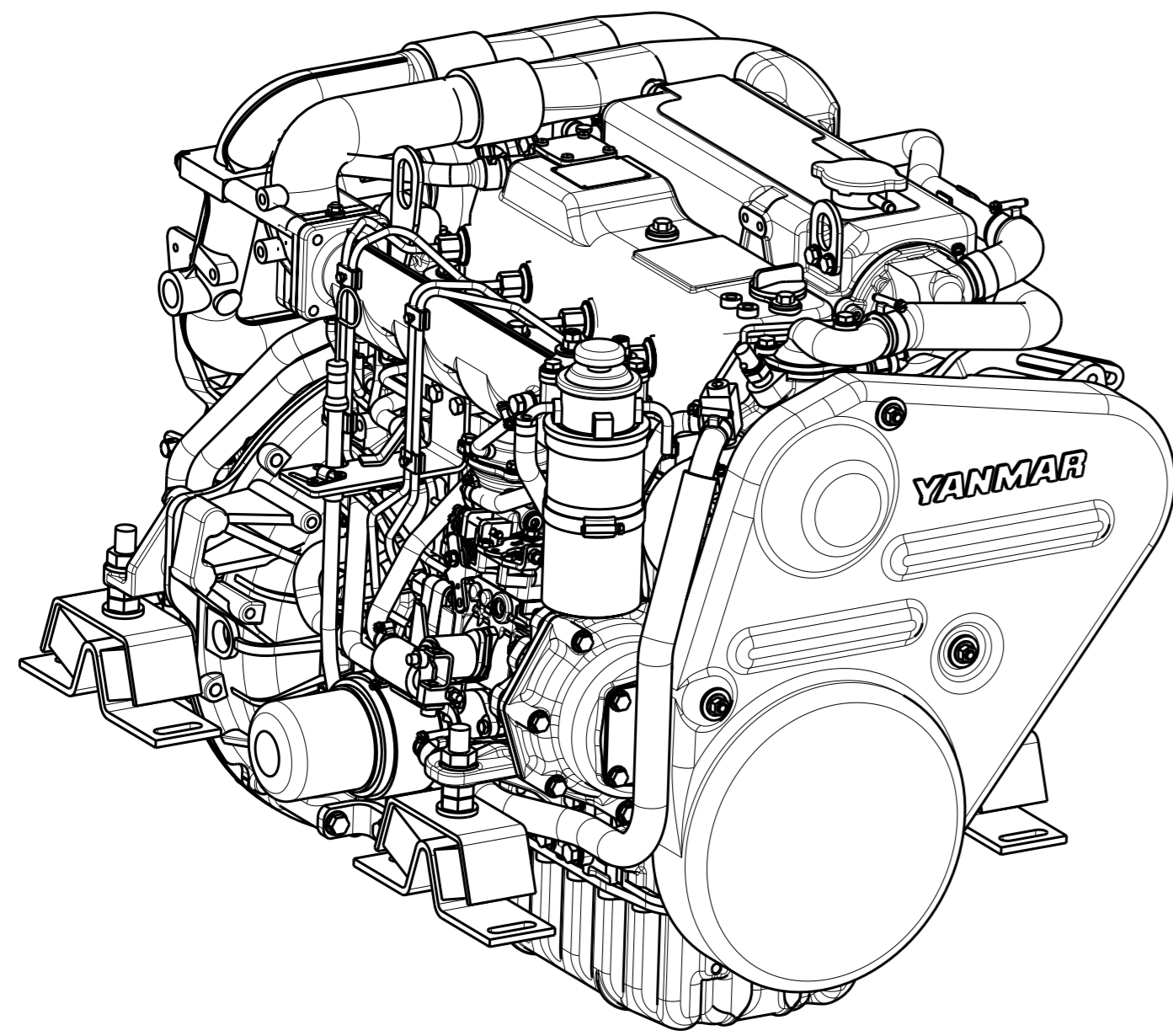
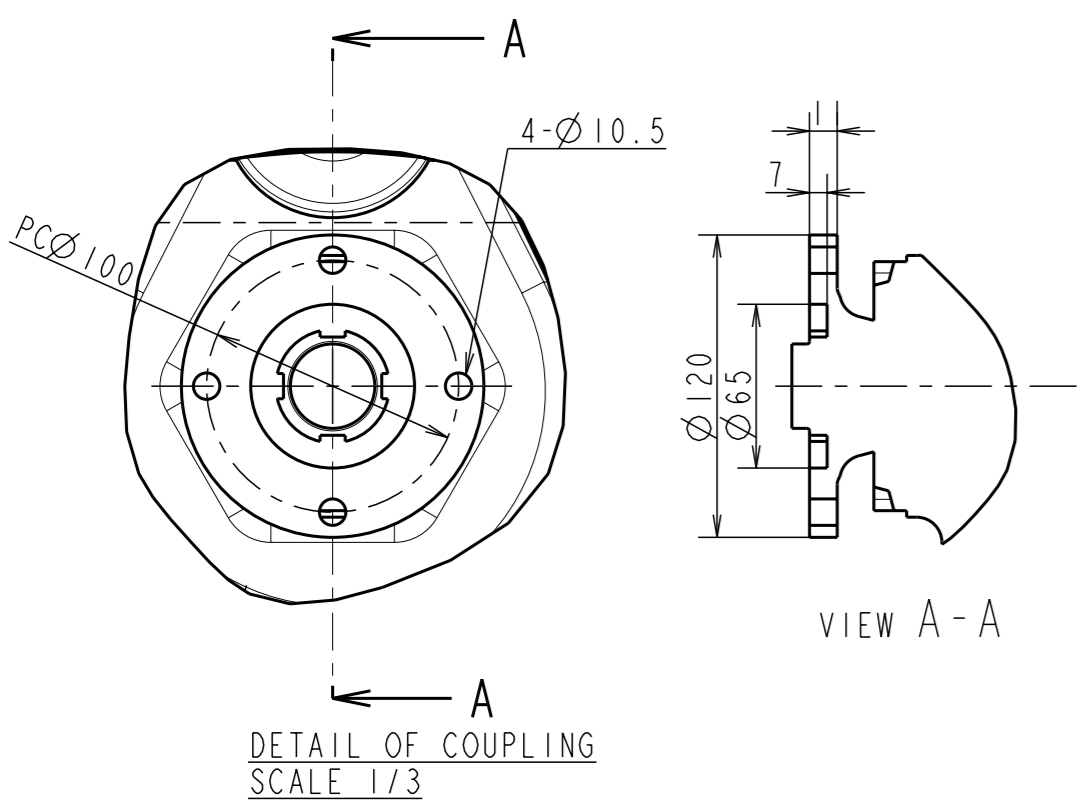

DIRECTION OF ROTATION

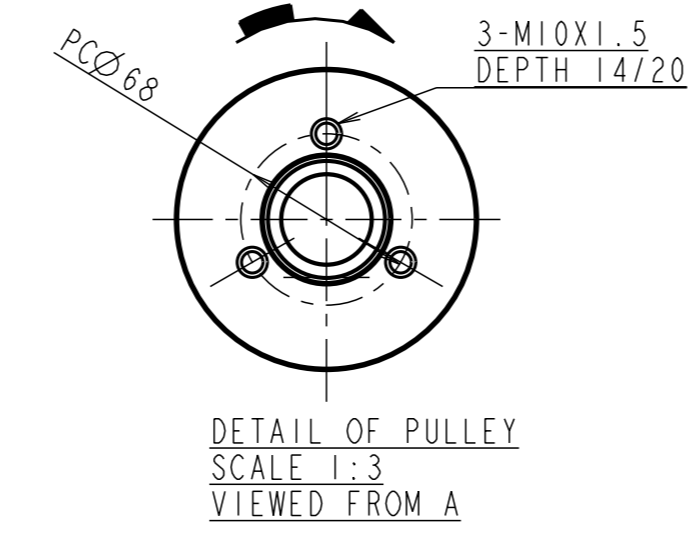

NOTE  
 1. DWG SHOWS MOUNTING BLOCKS AT ORIGINAL HEIGHT. ENGINE WEIGHT WILL COMPRESS BLOCKS BY 4MM(APPROX).  
 2. MOUNTING BLOCKS ARE EQUIPPED FOR STANDARD ACCESSORY.  
 3. THE FIGURES MARKED WITH \* SHOW THE DIMENSIONS WITH U-MIXING ELBOW, OR OPTIONAL COUPLING.  
 4.  $\bullet$  SHOWS THE CENTER OF GRAVITY.

SPECIFICATIONS		4JH4-HTE
Model		4JH4-HTE
Continuous Power(ISO 8665)	kW/min <sup>-1</sup>	73.6/3101
Fuel Stop Power	Propeller shaft(ISO 8665) kW/min <sup>-1</sup>	77.7/3200
	Crankshaft(ISO 8665) kW/min <sup>-1</sup>	80.9/3200
Reduction ratio		1.47 2.14 2.63
Dry mass	kg(lb.)	Approx. 247(545)
Direction of Crankshaft rotation		Counter-clockwise

MANAGER	MANAGER	SCALE	1:5
CHECKED	SPECIALIST	QTY	MATERIAL
DESIGNED	DRAWN	DATE:Y.M.D	NAME
YANMAR		REV.1	
YANMAR CO.,LTD. DEVELOPMENT DEPT.		CODE	B2-29672-0910
		DRAW SIZE	A1

3D-CAD

NOTICE	
GEOMETRICAL TOLERANCE	
KIND OF TOLERANCE	SYMBOL
STRAIGHTNESS TOLERANCE	
CIRCULARITY TOLERANCE	
PROFILE OF LINE TOLERANCE	
FLATNESS TOLERANCE	
CYLINDRICITY TOLERANCE	
PROFILE TOLERANCE OF SURFACE	
PARALLELISM TOLERANCE	
PERPENDICULARITY TOLERANCE	
ANGULARITY TOLERANCE	
POSITIONAL TOLERANCE	
COAXIALITY TOLERANCE	
SYMMETRY TOLERANCE	
CHIRALITY TOLERANCE	
ROTATIONAL TOLERANCE	